

Our Largest Capacity

Glassboy 850 [850kg]

From glass installation work and shop front glazing, to fitting loads below an overhang and general workshop lifting, the Glassboy 850 floor crane is a reliable lifting aid that suits a range of below-the-hook devices such as Liffey Crane Hire's vacuum lifters.

With the ability to handle loads of up to 850kg and a maximum hook height of 2.8m, the Glassboy 850 can also be positioned between floors or on rooftops and can be used with an electric hoist to raise loads from the ground up.

This compact floor crane comes with a **long wheel** or **short wheel** base and sees the addition of outriggers for stabilising during lifting. The Glassboy 850 includes a hand pump that can be relocated to be close to the load or away from the load as required.

It is a truly versatile counterbalanced floor crane thanks to its flexibility to assist in a broad range of applications.



Features include a moveable hand pump.



Glassboy 850 Short Wheel Base Configuration With Standard Castor Wheels



The Glassboy 850 features outriggers for stabilising during lifting

Technical Specifications

Safe working load	capacity:	850kg
Weight of floor crane (long chassis)	weight:	794kg (with 20 counterweights) 556kg (with 10 counterweights) 310kg (with no counterweights)
Weight of floor crane (short chassis)	weight:	778kg (with 20 counterweights) 540kg (with 10 counterweights) 294kg (with no counterweights)
Minimum Outreach	length:	210mm
Maximum Outreach	length:	900mm
Counterweights	control:	1 box: 10x22kg / 2 boxes: 20x22kg
Standard accessories	standard:	removable transport wheels

Capacities At Each Working Length

Long Version

Pos.	Solid Wheel Outreach	Castor Wheel Outreach	1 Box	2 Boxes
1	210mm	250mm	550kg	850kg
2	500mm	540mm	400kg	780kg
3	620mm	660mm	350kg	710kg
4	740mm	780mm	300kg	640kg
5	860mm	900mm	280kg	580kg

Capacities At Each Working Length

Short Version

Pos.	Solid Wheel Outreach	Castor Wheel Outreach	1 Box	2 Boxes
1	210mm	250mm	350kg	750kg
2	500mm	540mm	250kg	480kg
3	620mm	660mm	220kg	450kg
4	740mm	780mm	200kg	380kg
5	860mm	900mm	170kg	350kg

Note: Castor wheels must be facing forwards to accomplish the above capacities and reach.

Floor Crane

Glassboy 850

Key Features

- Capacity: 850kg
- Easy to assemble and highly portable
- Long or short wheel base
- Long Wheel Base Weight: 794kg approx. (with 20 counterweights), 310kg approx. (without counterweights)
- Short Wheel Base Weight: 778kg approx. (with 20 counterweights), 294kg approx. (without counterweights)

The Glassboy 850 boom is raised and lowered using a movable hand pump



Glassboy 850 Long Wheel Base Configuration With Optional Rubber Tyres



The Glassboy 850 can be used in a short or long wheel base configuration

Technical Data - Solid Wheels (mm)

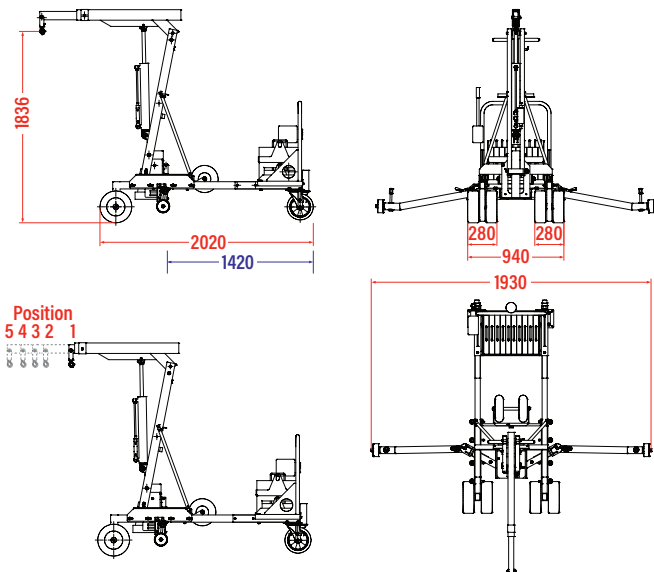

Technical Data - Castor Wheels (mm)

