

Bestseller Built For Saf

P11104 "Four-In-Line" Dual Circuit [320kg]

This bestselling glass vacuum lifter is a convenient tool for lifting glass, metal, ceramics and other non-porous materials. The P11104 enables users to quickly manoeuvre loads into position with its 180° lockable rotation and 90° tilt.

Engineered and tested for its reliability, safety and durability, the P11104 lifter comes with a 320kg lifting capacity and on-board power with a rechargeable battery, so there are no tricky cords to deal with during operation.

An optional short hook is also available when fitting glass under soffits or overhangs.

Key Features

- Capacity: 320kg
- Dual circuit vacuum system with reserve tank, non-return valve and vacuum gauge for each circuit
- 90° manual tilting from vertical to horizontal
- 180° rotation, lockable in three positions
- Integral maintenance-free vacuum pump
- 12v rechargeable battery with integral 110v or 240v charger and battery energy gauge
- Audio-visual low vacuum warning
- On-board control panel

Reference Code

VGL11



Technical Specifications

Safe working load (smooth, clean surface at 60% vacuum)	capacity:	320kg
Number of suction cups	cups:	4
Suction cup	description:	black rubber, not abrasion resistant, heat resistant up to 100°F
Suction cup diameter	diameter:	305mm
Suitable for lifting	material properties: surface: example:	gastight / non-porous smooth glass, plastic boards, ceramic plates, sheet metals, coated boards
Weight of lifter	approx:	34kg
Depth of lifter	depth:	233mm
Rotation	rotation:	90° manual left & right lockable
Tilt	tilt:	90° manual
Vacuum system	dual circuit:	1 pump, 2 vacuum reserve tanks
Voltage	pump: battery charger:	12v DC from rechargeable battery 110v/240v 50/60Hz single phase factory selectable
Optional accessories	optional:	short hook, radio remote control, curved pads (270kg capacity), stone pads (270kg capacity), low marking pads, heat resistant pads

ety



Optional radio remote control

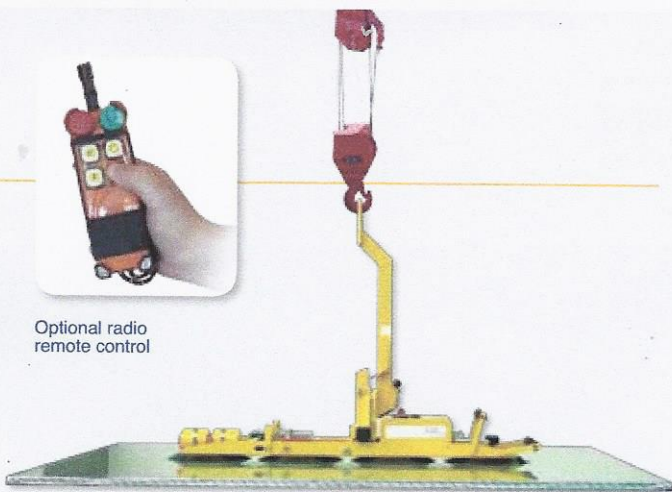

P11104 "Four-In-Line" Dual Circuit

Technical Data (mm)

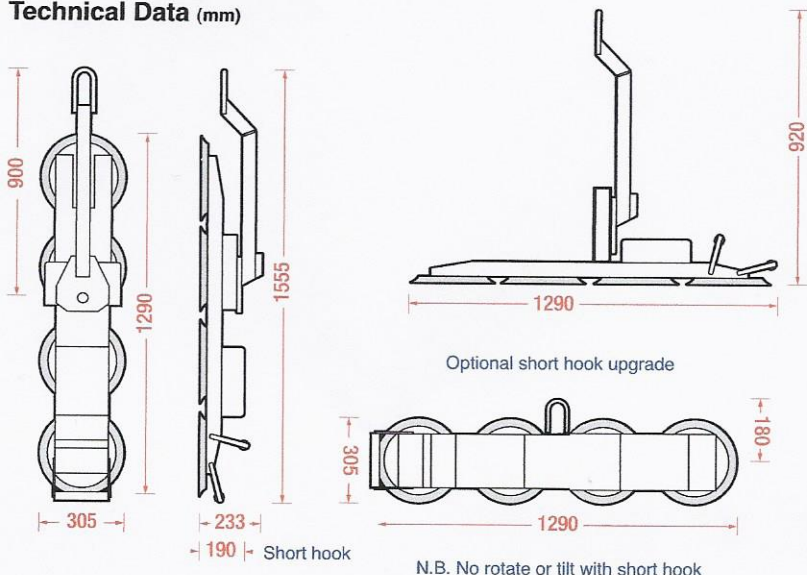

Lift Bar Option - 635kg

